

VEHICLE PROTECTION AND ANTI-THEFT DETECTION USING FACIAL RECOGNITION AND SHOCK MECHANISM

(Shaik.Salma)¹ (Mr. Dr. B.D Venkataramana Reddy)²

(M.Tech student)¹ (Professor)²

Electronics and Communication Engineering (ECE)

SIR VISHVESHWARAI AH INSTITUTE OF SCIENCE

AND TECHNOLOGY (SVTM)

Mail.id: (salmashaikbasha@gmail.com)¹ (balam.diguva@gmail.com)²

Abstract:

Now-a-days the usage of vehicles become more and everywhere we are seeing vehicles and traffic jams because of vehicles. In most of the families at least one vehicle will be there. Along with increase in vehicles theft of vehicles also becoming more and more. For every owner there is a fear of stealing their vehicles in houses or in any place. Some many techniques have been emerged for the detection of unauthorized persons. Among them facial recognition is best solution. It is the latest emerging technology in every field. In this paper we are implementing the same. The theft prevention can be done by facial recognition. If the face is not recognized then mail will be sent to the owner automatically and a shock mechanism will activate so that vehicle will be in safe condition.

Keywords: *Raspberry Pi, Camera, Surveillance Face Recognition.*

Introduction:

To ensure security of a vehicle to a greater extent, the system in the vehicle has to be upgraded technologically. At present, people are buying vehicles that are technologically futuristic with more options for comfort and safety. For once, comfort of the vehicle can be put hold but when it comes to safety then it becomes a crucial factor for the buyer/owner of the vehicle. Safety of the vehicles is challenged when it is tried to be stolen in absence of the owner and that is why many companies and technicians are trying to implement new techniques to conquer the theft of

vehicles getting stolen from parking spots of public areas.

The use of vehicle becomes important everywhere in the world and also preventing it from theft is required. Vehicle manufacturers are attaining the security features of their products by introducing advanced automated technologies to avoid the thefts particularly in case of cars. Biometric and non-biometric methods usually provide such security features. Sometimes these systems fail due to hacked password and encryption of decrypted data, but it is almost impossible to make replica of distinctive

characteristics. Biometric systems are modern and use techniques like fingerprint recognition, iris recognition and face recognition. Of these face recognition and detection systems are more sophisticated, easy to deploy and people can be identified without their knowledge. Some advantages of facial recognition method for vehicle security application are: - 1. More convenient, sensed as soon as one is seated in position.

2. Low cost and a better approach to be used with existing methods.

3. Requires no active part of the user. In vehicle security system, the objective is to prevent the theft of vehicle and ensure safety of vehicle by avoiding the means of theft. One level of ensuring authentication of driving is through face recognition system that authenticates a user being an authorized person to have access to the ignition system.

Existing system:

Car alarm techniques are used to prevent the car theft with the help of different type of sensors like pressure, tilt and shock & door sensors. These systems however bear some limitations such as high cost, high false alarm rate, and easy to be disabled. In order to solve these problem recent advancements in computer hardware and software have enabled automobile industry to develop affordable automated biometrics-based identification and verification systems. Many biometrics, including face detection, facial features, hand geometry, handwriting and voice have been used for the identification and verification of individuals. But biometric has its own disadvantages such as the systems are not 100% accurate, they require integration and/or additional hardware and cannot be reset once compromised, you can always change your password if somebody learns it, but there's no way to modify your iris, retina or fingerprint. Once somebody has a working copy of these, there's not much you can do to stay safe, other than switching to passwords or using another finger.

Disadvantages:

- ✓ Due to longer distance (range), siren cannot be heard
- ✓ Most of the cars have similar sounds, and physically
- ✓ Alarms can be disabled on theft attempts
- ✓ Alarm sound can be mitigated in crowded areas.
- ✓ Cost is high

Proposed System:

In this project we are using camera through which authorized and unauthorized can be known. In data base authorized person's images are stored and if the authorized person is detected then the motor will start, otherwise camera will capture images and will send it to the owner and shock will activate and buzzer will activate at a time to alert the persons.

Block Diagram:

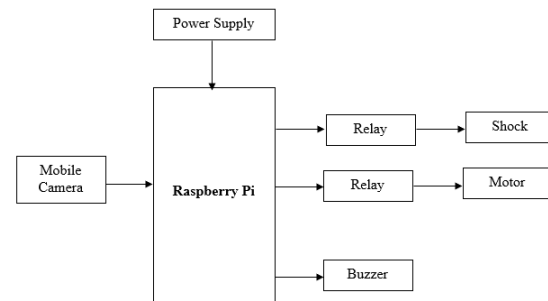

Fig1: Block Diagram

Hardware Requirements:

A) Raspberry Pi:

Raspberry pi is a powerful microcontroller that exists in credit card size. It serves as micro controller, also it serves as a minicomputer by connecting essential cables like HDMI cables, audio cable. Simply we can say Raspberry Pi is a credit card sized computer which also serves as microcontroller. It is fast as compared to other controllers.



Fig2: Raspberry Pi

B) 5V 2A Adapter:

5 Volt 2 Amp Power Adapter takes an AC INPUT of 100-240V and gives 5V 2A DC output.

Specifications: -

- Input - 100-240 VAC 50/60Hz
- Category - Switch Mode Power Adaptor (SMPS)
- Output Type - DC
- Output - 5Volts 2Amp



Fig3: 5V 2A Adapter

C) USB Cable:



Fig4: USB Cable

D) Relay:

A relay is an electromagnetic switch that is used to turn on and turn off a circuit by a low power signal, or where several circuits must be controlled by one signal.

Most of the high-end industrial application devices have relays for their effective working. Relays are simple switches which are operated both electrically and mechanically. Relays consist of an electromagnet and also a set of contacts.

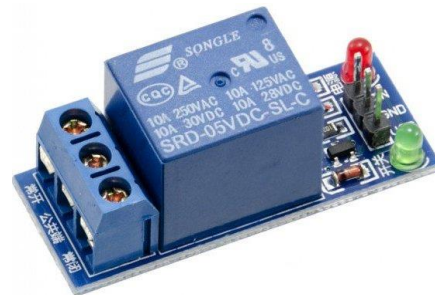

Fig5: Relay

Software Requirements

A) Python:

Python is an interpreter, high level, interactive and general-purpose programming language. It was developed by Guido van Rossum during 1985 – 1990. The source code is available under general public License. Python is named after a TV Show ‘Monty Python’s Flying Circus’ and not after Python-the snake. It supports Object Oriented programming approach for developing applications.

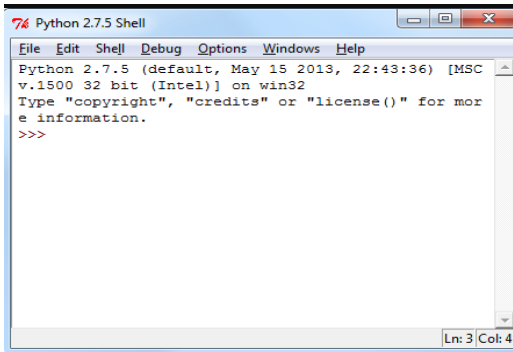

Fig6: Python Shell

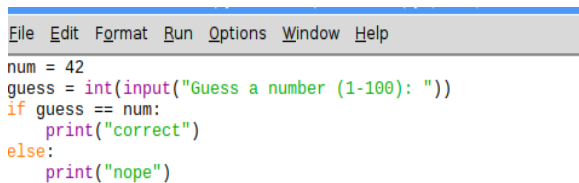

Fig7: Python Script

Advantages

- More convenient, sensed as soon as one is seated in position.
- Low cost and a better approach to be used with existing methods.
- The proposed system provided security and better theft control by using facial recognition and when the unauthorized person tries to start the ignition and will be notified.

Applications

- Jewelry Shops
- Shopping malls
- Apartments
- Theatres

Conclusion

Vehicle theft detection is very important for the society where transportation is essential. From the given system in this work safety can be achieved and it is also system with very less maintenance cost. Using this system work for theft detection future applications can be

developed and it is vital for IoT oriented system applications.

Future Scope

In future we can include vibration sensor in the system, which can detect the intensity of vehicle hitting an object. If the intensity exceeds certain level, it detects accident and can send SMS to relatives.

References

- [1] LEE, Sangwon; YOON, Dukhee; GHOSH, Amitabha. Intelligent parking lot application using wireless sensor networks. In: Collaborative Technologies and Systems, 2008. CTS 2008. International Symposium on. IEEE, 2008. p. 48-57.
- [2] TANG, Vanessa WS; ZHENG, Yuan; CAO, Jiannong. An intelligent car park management system based on wireless sensor networks. In: Pervasive Computing and Applications, 2006 1st International Symposium on. IEEE, 2006. p. 65-70.
- [3] BENSON, Jonathan P., et al. Car-park management using wireless sensor networks. In: Local Computer Networks, Proceedings 2006 31st IEEE Conference on. IEEE, 2006. p. 588-595.
- [4] C. Nandakumar, G. Muralidaran and N. Tharani "Real Time Vehicle Security System through Face recognition" Division of Mechatronics, Department of Production Technology, Madras Institute of Technology, Anna University, Chennai, INDIA.
- [5] A. PazhampillySreedevi, B. Sarath S Nair "Image Processing Based Real Time Vehicle Theft Detection and Prevention System".
- [6] D. Narendar Singh, K. Tejaswi "Real Time Vehicle Theft Identity and Control System Based on ARM 9" International journal of latest trend in engineering and technology (IJLTET).